

# BPR-Cadillon

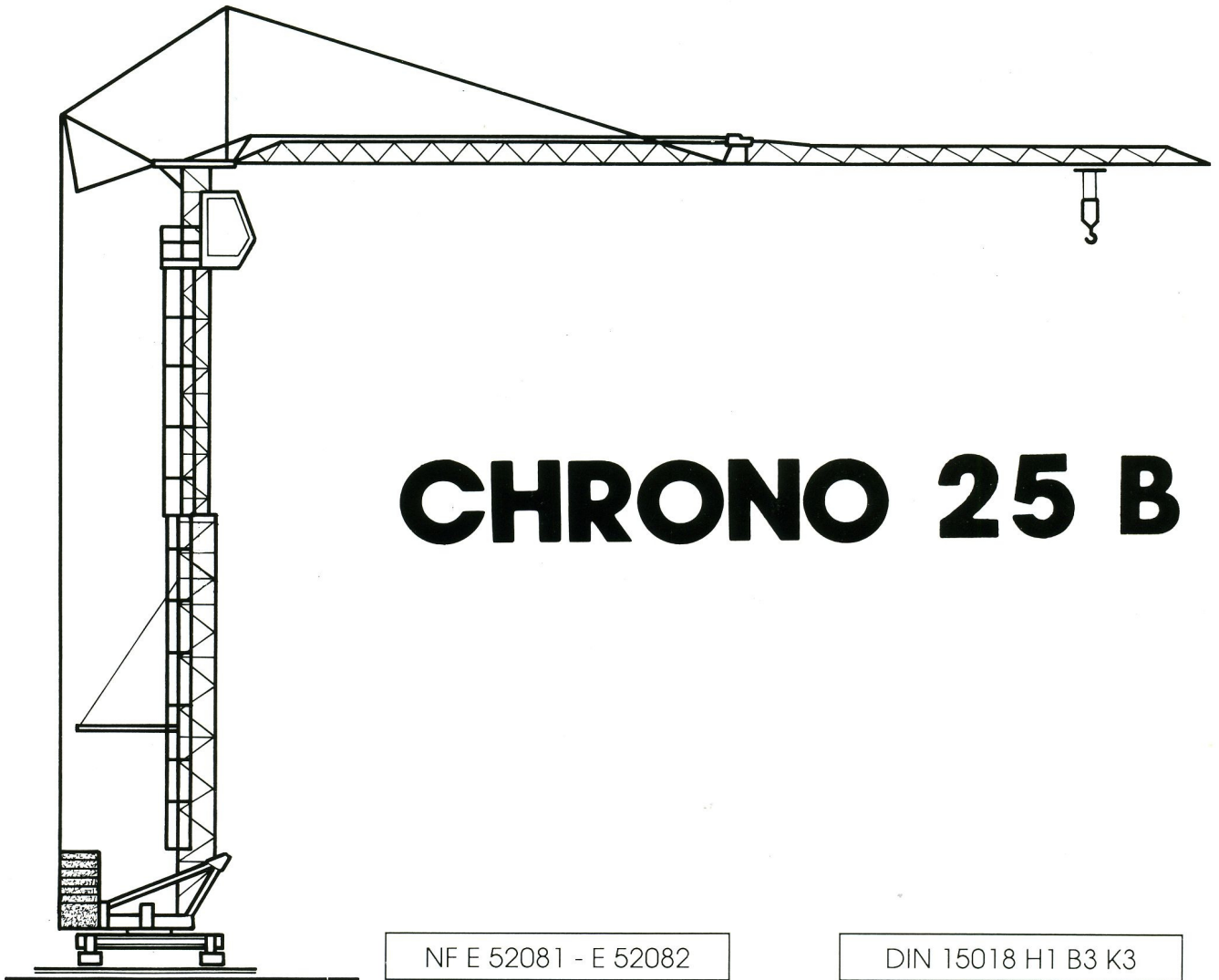

## CHRONO 25 B

NF E 52081 - E 52082

DIN 15018 H1 B3 K3

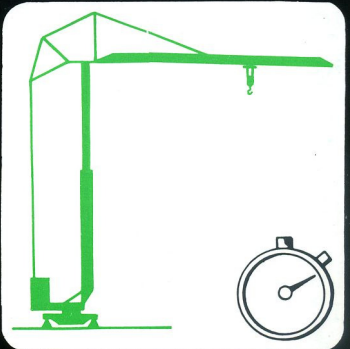
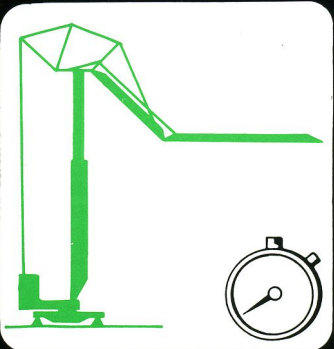
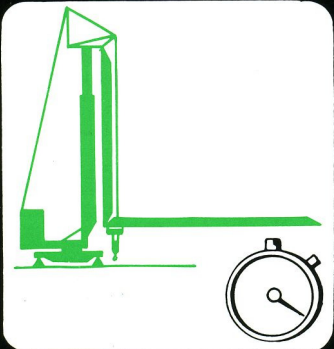
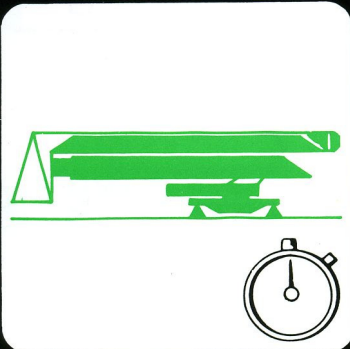





# CHRONO 25 B

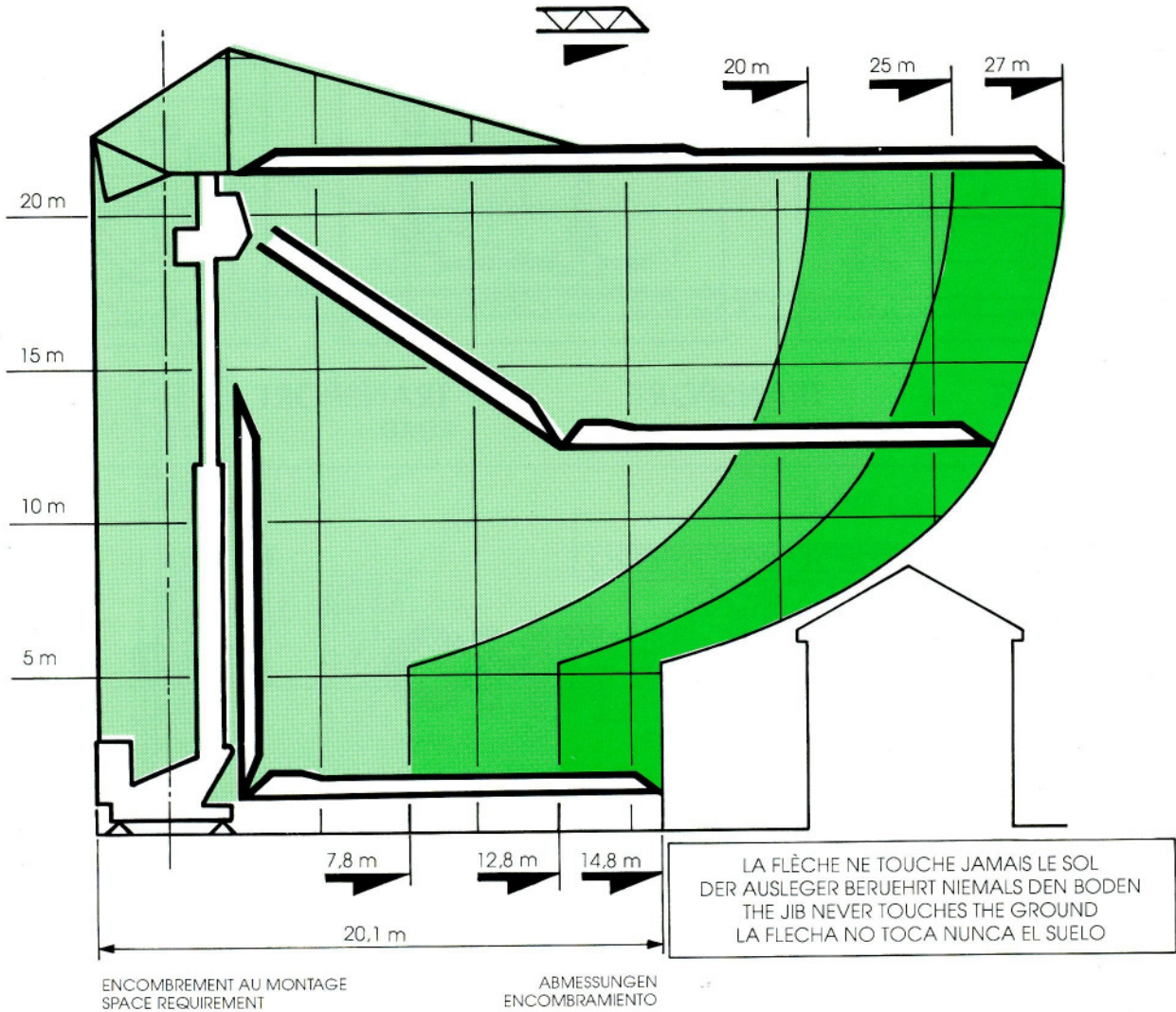

CHRONO 25 B		m/mn	KW	ch PS - HP	kg
	I	5	4	5,5	3000
	II	18	11	15	3000
	III	36	15	20	1500
tr/mn U/mn		0,2 > > 1	2,2	3	
		0 > > 35	2,2	3	
Option Kaufoption		I 17,5 II 35	1,1 2,2	3 3	
		0 > > 30	2 X 2,2	2 X 3	

V	380	450
Hz	50	60
kVA	23	28

GROUPE ELECTROGENE STROMAGGREGAT GENERATOR SET GRUPO ELECTROGENO		
V	380	450
Hz	50	60
kVA	46	56



# CHRONO 25 B

## VERSIONS SUR CHASSIS

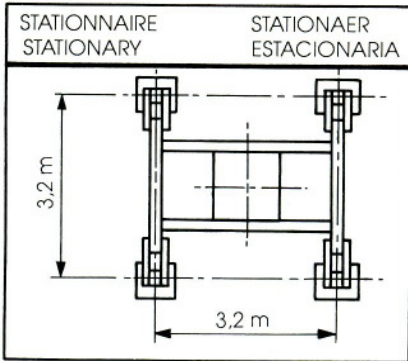

## UNTERWAGEN

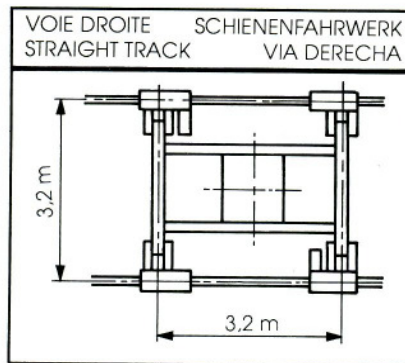

## UNDERCARRIAGE

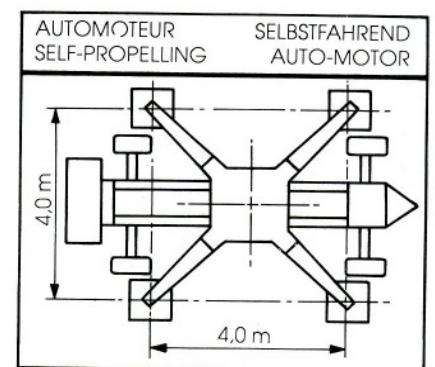

## CHASIS

## TRANSPORT ROUTIER

## TRANSPORT STRASSE

## TRANSPORT ROAD

## TRANSPORTE RUTA

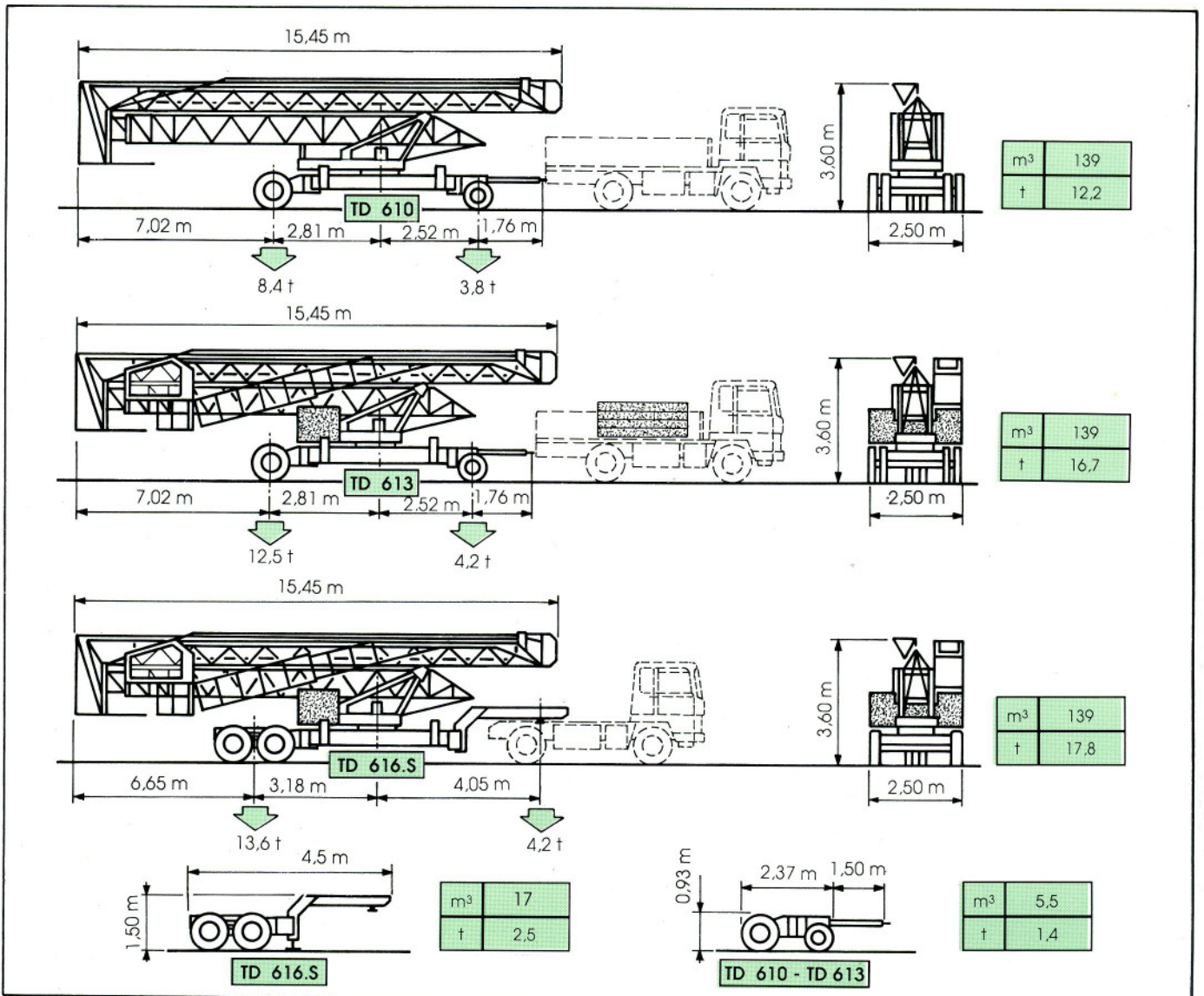

Modifications réservées - Änderungen vorbehalten - Subject to modification - Modificaciones reservadas

 **BPR-Cadillon**

GRUPE LEGRIS INDUSTRIES

Siège social : 17, rue de Verdun - BP 25 - 71120 CHAROLLES - France  
 Tél. : 85 24 09 34 - Téléx : 800 418 - Fax : 85 88 34 10  
 138, rue Julian Grimau - 94408 VITRY-SUR-SEINE Cedex - France  
 Tél. : (1) 45 73 39 70 - Téléx : 260 728 - Fax (1) 46 73 39 79  
 11, rue de la Ligne de l'Est - BP 1064 - 69613 VILLEURBANNE Cedex  
 Tél. : 72 34 99 00 - Téléx : 370 242 - Fax : 72 34 99 20  
 CADILLON BAUMASCHINEN G.m.b.H. : Am Dornbusch 4 - D 6108 WEITERSTADT  
 Tél. 0 6151 85041 ou 85042 ou 85043 - Télécopie 0 6151 82535 - Téléx 041419223 +

DATA N° 284.14.291